

UCG 150 - 12

12V 150AH

AGM GEL

Ultracell®

'Quality in Every Language'

Image



Terminal Type

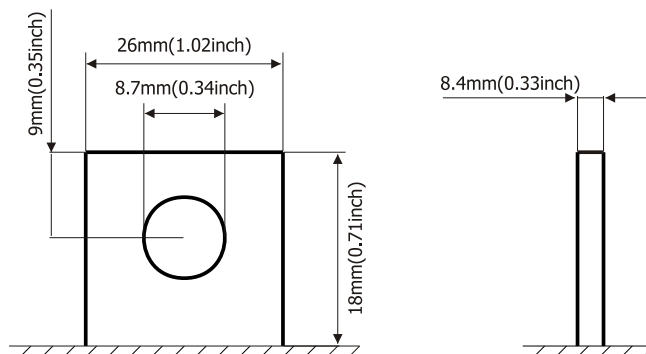

Dimensions

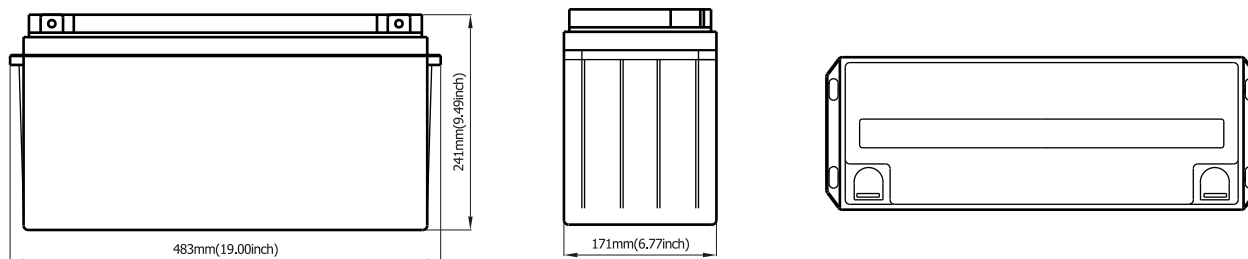

Specifications

Battery Model	UCG 150 - 12			
Designed Floating Life	15 Years			
Capacity (25°C)	20HR (7.8A, 1.75V)	10HR (15.3A, 1.75V)	5HR (28A, 1.75V)	1HR (97.5A, 1.75V)
	156AH	153AH	140AH	97.5AH
Dimensions	Length	Width	Height	Total Height
	483mm	171mm	241mm	241mm
Approx. Weight	45Kg			
Internal Resistance	Fully Charged at 25°C 0.004 Ohm			
Self Discharge	3% of capacity declined per month at 25°C			
Capacity Affected by Temperature	40°C	25°C	0°C	-15°C
	102%	100%	85%	65%
Charge Voltage (25°C)	Cycle Use		Float Use	
	14.4-15V (-30mV/C), max. Current: 37.5A		13.6-13.8V (-20mV/C)	

Construction

Component ——— Raw material
 Positive ——— Lead dioxide
 Negative ——— Lead
 Container ——— ABS (Flame Retardent optional)
 Cover ——— ABS (Flame Retardent optional)

Sealed and maintenance free option

Sealant ——— Epoxy Resin
 Safety Valve ——— EPDR
 Terminal ——— Copper
 Separator ——— Fibre Glass
 Electrolyte ——— Sulphuric acid and Gel

Non-spillable construction design



CE 1188



MH 29410

Tel | +44 (0) 151 523 2777
Fax | +44 (0) 151 523 0855
E-mail | info@ultracell.co.uk
Web | www.ultracell.co.uk

UCG 150 - 12

12V 150AH

AGM GEL

Ultracell®

'Quality in Every Language'

Charge Characteristic

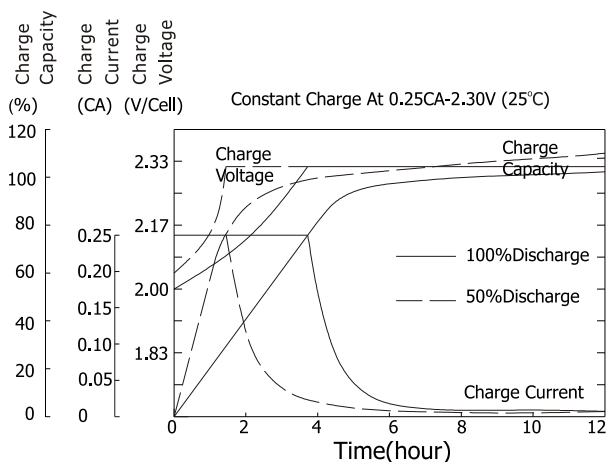

Discharge Characteristic 25°C

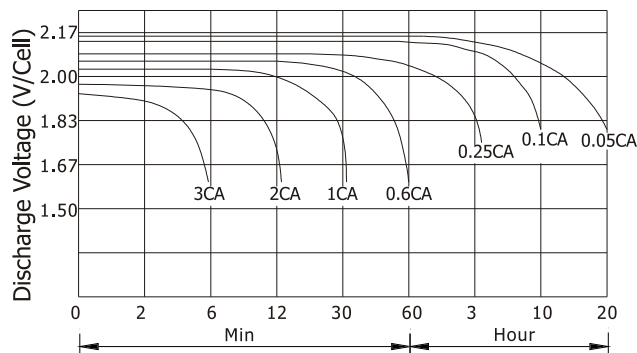

Relationship of OCV and state of charge

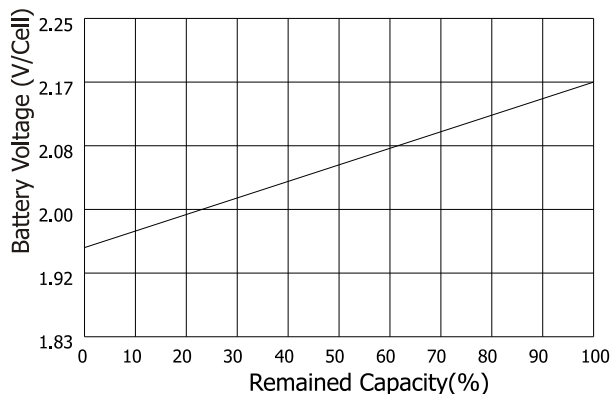

Life Expectancy Cycle Use:

- 100% depth of discharge 350 cycles
- 80% depth of discharge 600 cycles
- 50% depth of discharge 900 cycles
- 30% depth of discharge 1500 cycles
- 20% depth of discharge 1700 cycles

Constant Current Discharge Ratings - amperes at 25°C

F.V / Time	5 MIN	10 MIN	15 MIN	30 MIN	1 HR	3 HR	5 HR	10 HR	20 HR
1.60 V	591	363	275.1	167.7	90.2	46.8	27.9	15.3	8.40
1.67 V	549	348	266.7	160.8	89.1	39.6	27.4	15.0	8.10
1.70 V	507	333	258.3	145.8	85.8	37.6	26.4	14.7	8.10
1.75 V	501	324	249.9	138.9	84.0	36.6	25.7	14.4	7.70
1.80 V	444	309	227.1	128.7	78.3	35.7	25.2	14.4	7.70
1.85 V	393	293.4	203.4	117.9	75.9	35.1	25.2	14.4	7.70

Constant Power Discharge Ratings - watts at 25°C

F.V / Time	5 MIN	10 MIN	15 MIN	30 MIN	1 HR	3 HR	5 HR	10 HR	20 HR
1.60 V	1200	780	600	348	195	75.9	51.6	29.1	15.3
1.67 V	1161	762	591	342	192.9	75.6	21.3	29.1	15.3
1.70 V	1113	750	576	336	190.8	75.0	51.3	28.8	15
1.75 V	1047	720	558	327	187.8	74.4	51.2	28.8	15
1.80 V	909	666	534	318	181.8	72.9	51	28.7	15
1.85 V	858	618	510	303	177.6	71.7	51.0	28.2	14.8



CE 1188



MH 29410

Tel +44 (0) 151 523 2777
 Fax +44 (0) 151 523 0855
 E-mail info@ultracell.co.uk
 Web www.ultracell.co.uk